



Shipping Warehouse: Slater Road, Ferndale, WA 98248, USA
 Corporate Head Office: Suite 201, 3020-152nd Street Surrey BC Canada V4P 3N7
 Tel, 604-542-8945 Fax 1 866 226-1649
 E-mail: sales@firgelliauto.com www.FirgelliAuto.com

Track Actuator Kit



- 200 to 450lbs force
- Plug and play out of the box Linear Actuator
- Simple mounting options, using screw holes on either side of the sliding block
- Very Low noise design
- Powder metal gears
- Compatible with our remote control system (4CH-RC) by using relays
- IP20 rating, indoor usage recommended.
- Includes plug in power supply, and wired hand controller.

Specifications

Type	FA-200-TR-24-XX (STANDARD MODEL)	FA-400-TR-24-XX (discontinued MODEL)	FA-450-TR-24-XX (STANDARD MODEL)
Input	24VDC	24VDC	24VDC
Load capacity	889.64N (200 LBS)	1779.29N (400 LBS)	2001.70N (450 LBS)
Speed at no load	2.5"/sec no load 1"/sec full load	.5"/sec no load .2"/sec full load	0.39"/sec no load 0.14"/sec full load
Stroke length	10/20/30/40 inch	10/20/30/40 inch	10/20/30/40 inch
Mounting	See drawing below	See drawing below	See drawing below
Limit switch	Built in	Built in	Built in
Duty cycle	20%	20%	20%
Static load	75 lbs	300 lbs	350 lbs
Main tube	Aluminum Alloy	Aluminum Alloy	Aluminum Alloy
IP Grade	IP20	IP20	IP20
Operation Temperature	-26C to +65C	-26C to +65C	-26C to +65C
Safety Certificate	CE, ROHS	CE,ROHS	CE, ROHS

MB5 mounting bracket kit will only fit track actuators

CSPSRCMS kit will only fit track actuators

Stroke/weight

Stroke length	10	20	30	40
Weight	2800 g	3590 g	4380 g	5170 g

LOAD/CURRENT

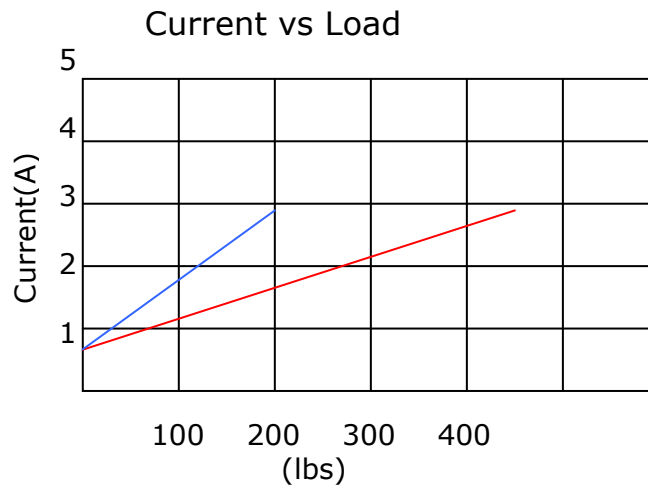

LOAD/SPEED

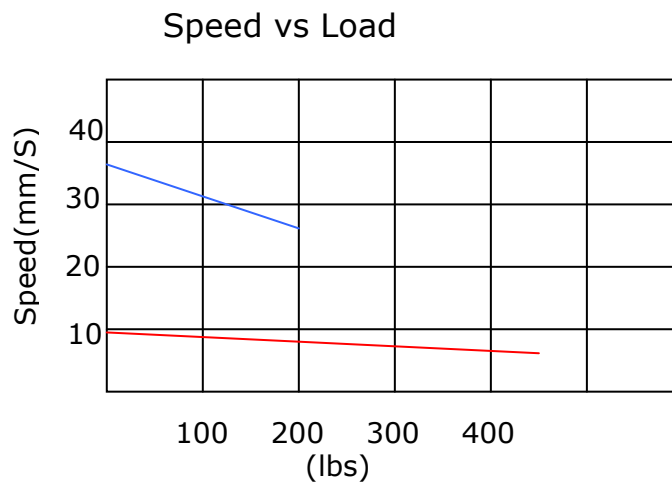

Dimensions Imperial:

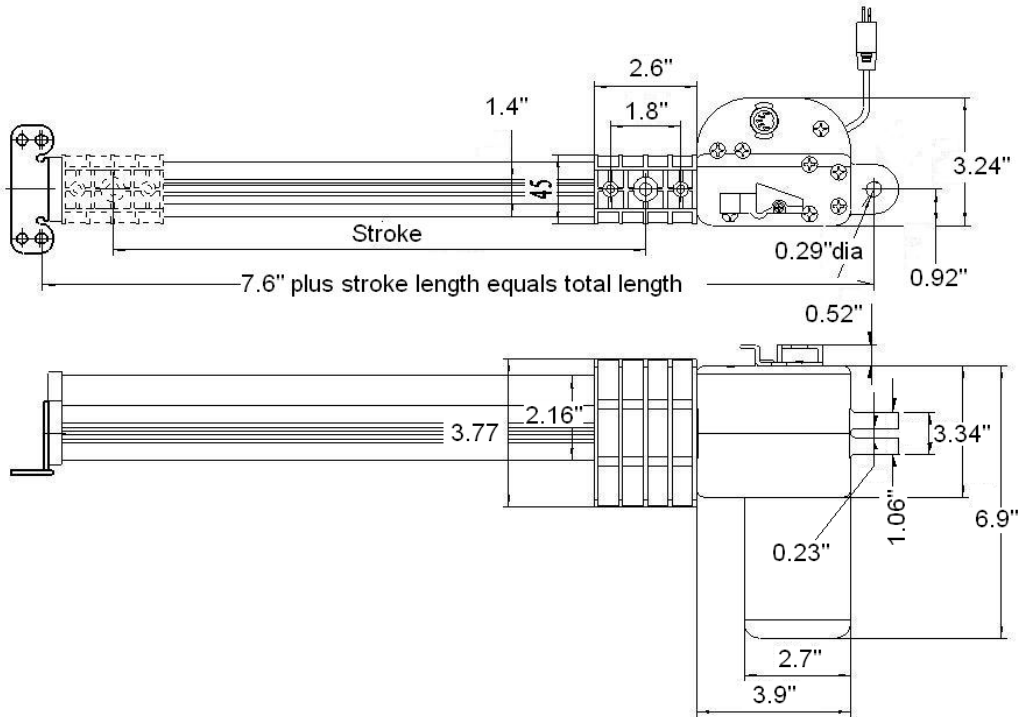

Dimensions metric:

